



ITT

en **VOGEL-Submersible Sewage Pumps**
Model: 100 TWS, 100 TWM, 100 TWV

Installation, Operation and Maintenance
Instruction

Translation of the Original Operation Manual



en **Keep for further use !**
Pay attention to this operating instruction before the delivery, installation, start-up a.s.o.!

EC Declaration of Conformity (valid only for ITT Austria aggregate supplied in its entirety)
(according to **EC Directive on Machinery 2006/42/EC, Annex II A**)



The manufacturer,
ITT Austria GmbH
Ernst Vogel-Strasse 2
A-2000 Stockerau, Austria

of the pumps from the standard product line hereby declares:

100 TWS, 100 TWM, 100 TWV

- The supplied aggregates meet the relevant regulations of the EC Directive on Machinery, 2006/42/EC
- The three-phase electric motor supplied at the same time meets the relevant regulations of Directive 2006/95/EC.
- Special technical documentation has been prepared, in accordance with Annex VII A.
- If necessary, we can submit the above-listed special technical documentation, in electronic form on a data storage medium, to the relevant authorities.
- The above-listed special documentation can be requested at the following address:
Dipl. Ing. Gerhard Fasching
Abtlg. Research & Development
ITT Austria GmbH
Ernst Vogel-Strasse 2
A-2000 Stockerau, Austria

- Among others, the following harmonised standards have been applied:
EN 809
EN 953
EN ISO 12100, part 1
EN ISO 12100, part 2
EN 60204 part 1

- A change to an aggregate which was not approved by us invalidates this declaration. This also applies in the case that the aggregate is installed in equipment that does not have the declaration of conformity in accordance with the Directive on Machinery, 2006/42/EC.

In Stockerau, 15 January 2010

Robert Salzbauer
Quality Control Department

Table of Contents

1. GENERAL	5
1.1 FOREWORD	5
1.2 GUARANTEE	5
1.3 SAFETY REGULATIONS	5
1.4 SAFETY INSTRUCTIONS	6
DANGERS OF NOT FOLLOWING SAFETY INSTRUCTIONS	6
SAFETY INSTRUCTIONS FOR THE OPERATOR	6
SPEED, PRESSURE, TEMPERATURE	7
MINIMUM FLOWS	7
BACK FLOW	7
2. DESCRIPTION	7
2.1 MODEL	7
EMPLOYMENT	7
2.2 BEARING AND LUBRICATION	8
BEARING	8
OIL FILLING	8
LUBRICANT LIST	8
2.3 SHAFT SEALING	8
2.4 INSTALLATION METHODS	9
2.5 TECHNICAL DATA	9
MOTOR	9
WET INSTALLATION	9
DRY INSTALLATION	10
3. TRANSPORT, HANDLING STORAGE	10
3.1 TRANSPORT, HANDLING	10
CHECKING THE OIL FILLING	11
3.2 STORAGE	11
4. INSTALLATION, OPERATION	11
4.1 ASSEMBLY AND CONNECTION OF PUMP	11
MOUNTING OF DISCHARGE PIPE AND/OR SUSPENSION DEVICE AT PUMPS OF DESIGN TWS	12
4.2 CONNECTING THE PIPES TO THE PUMP	12
4.3 MOUNTING OF PUMP BY MEANS OF SUSPENSION DEVICE	12
4.4 ELECTRICAL CONNECTION	12
MOTOR PROTECTION	12
SENSE OF ROTATION	13
DESIGNATION OF CONNECTION	13
CONTROL	14
ALARM SWITCHES	14
MOUNTING OF LEVEL SWITCHES	14

Operating Instructions

ELECTRICAL CONNECTION	15
4.5 STARTING UP	15
STARTING UP FOR THE FIRST TIME	15
RESTARTING	16
4.6 OPERATION AND MONITORING	16
4.7 SHUTTING DOWN	16
4.8 DISMANTLING	16
5. MAINTENANCE, SERVICING	17
CHANGE OF OIL	17
CLEANING THE PUMP	17
GENERAL OVERHAUL	17
ALARMS	17
6. LONGER PERIODS OF NON-OPERATION	18
6.1 PUMPS WHICH HAVE NOT BEEN INSTALLED	18
6.2 PUMPS WHICH HAVE BEEN INSTALLED	18
7. FAULTS - CAUSES AND SOLUTIONS	18
8. REPAIRS	19
9. SPARE PARTS, SPARE PUMPS	19
9.1 SPARE PARTS	19
ORDERING SPARE PARTS	20
9.2 STAND-BY PUMPS	20
10. PLANT MANAGER LIST	20
11. LOG BOOK	21
SECTIONAL DRAWING WITH LEAKAGEDETECTOR 100TW	22
BRANCH OFFICES	24

1. General

1.1 Foreword

This product complies with the safety requirements of EC Machinery Directive 89/392/EEC, 91/368/EEC, 93/44 EEC and the Austrian Machine Safety Order (MSO) of 27 April 1994.



The staff employed on installation, operation, inspection and maintenance must be able to prove that they know about the relevant accident prevention regulations and that they are qualified for this work. If staff do not have the relevant knowledge, they should be provided with suitable instructions.

The operating safety of the pumps or units (i.e. pump plus motor) supplied is only guaranteed if these are used in accordance with the provisions given in the Confirmation of Order and/or Point 4 in "Installation and Operation".

The operator is responsible for following the instructions and complying with the safety requirements given in these Operating Instructions.

Smooth operation of the pump or pump unit can only be achieved if installation and maintenance are carried out carefully in accordance with the rules generally applied in the field of engineering and electrical engineering.

If not all information can be found in these Operating Instructions, please contact us.

The manufacturer takes no responsibility for the pump or pump unit if the Operating Instructions are not followed.

These Operating Instructions should be kept in a safe place for future use.

If the pump or pump unit is handed on to any third party, it is essential that these Operating Instructions and the operating conditions and working limits given in the Confirmation of Order are also passed on in full.

These Operating Instructions do not take into account all design details and variants nor all the possible chance occurrences and events which might happen during installation, operation and maintenance.

Alterations or changes to the machine are only permitted by agreement with the manufacturer. Original spare parts and accessories authorised by the manufacturer should be used for more safety. We bear no responsibility for the consequences of using other parts.

We retain all copyright in these Operating Instructions; they are intended only for personal use by the owner of the pump or the pump unit. The Operating Instructions contain technical instructions and drawings which may not, as a whole or in part, be reproduced, distributed or used in any unauthorised way for competitive purposes or passed on to others.

1.2 Guarantee

The guarantee is given in accordance with our Conditions of Delivery and/or the confirmation of order.

Repair work during the guarantee period may only be carried out by us, or are subject to our written approval. Otherwise the guarantee ceases to apply.

Longer-term guarantees basically only cover correct handling and use of the specified material. The guarantee shall not cover natural wear and tear and all parts subject to wear, such as impellers, shaft sealings, shafts, shaft sleeves, bearings, wear rings etc., or damage caused by transport or improper handling.

In order for the guarantee to apply, it is essential that the pump or pump unit is used in accordance with the operating conditions given on the type plate and in the Confirmation of Order. This applies particularly for the endurance of the materials and smooth running of the pump and shaft sealing.

If one or more aspects of the actual operating conditions are different, we should be asked to confirm in writing that the pump is suitable.

1.3 Safety regulations

These Operating Instructions contain important instructions which must be followed when the pump is assembled and commissioned and during operating and maintenance. For this reason, these Operating Instructions must be read by the skilled staff responsible and/or by the operator of

the plant before it is installed and commissioned, and they must be left permanently ready to hand at the place where the pump or pump unit is in use. The operator must ensure that the contents of the Operating Instructions are fully understood by the staff. The operator must confirm this by signing the "Plant Manager List" (see Point 10). These Operating Instructions do not refer to the General Regulations on Accident Prevention or local safety and/or operating regulations. The operator is responsible for complying with these (if necessary by calling in additional installation staff).

The safety instructions contained in these Operating Instructions have the following special safety markings as specified in DIN 4844:



Warning against personal accidents which could occur if the safety instructions given in this part of the Operating Instructions are not followed.



Warning against dangerous electrical voltage.

Attention **Warning against possible damage to property or the environment.**

It is absolutely essential that safety information affixed directly to the pump or pump unit is followed and maintained so that it is always easily legible.

All operation instructions of accessories (e.g. for motors) possibly enclosed must be followed and held available in the same way as this operation instruction.

1.4 Safety instructions

Dangers of not following safety instructions

Failure to follow the safety instructions can result in the following, for example:

- People being at risk because of electrical, mechanical, thermionic and chemical factors.
- Important functions of the pump or pump unit failing.
- Dangers to the environment as a result of dangerous substances leaking out.

Safety instructions for the operator

- **Never put hands or objects in the pump!**
- Depending on the operating conditions, wear and tear, corrosion or age will limit the working life of the pump/pump unit, and its specified characteristics. The operator must ensure that regular inspection and maintenance are carried out so that all parts are replaced in good time which would otherwise endanger the safe operation of the system. If abnormal operation or any damage are observed, the pump must cease operation immediately.
- If the breakdown or failure of any system or unit could lead to people being hurt or property being damaged, this system or unit must be provided with alarm devices and/or spare modules, and it should be tested regularly to ensure that it functions properly.
- If there is any risk of injury from hot or cold machine parts, these parts must be protected against contact by the user, or suitable warning signs must be affixed.
- Contact protection on moving parts (e.g. coupling guards) must not be removed from systems that are in operation.
- If the sound level of a pump or aggregate is above 85 dB(A) an ear protection has to be used when staying near the pump for some time.
- If dangerous media (e.g. explosive, toxic, hot) leak out (e.g. from shaft seals), these must be directed away so that there is no danger to people or the environment. The provisions of the law must be observed.
- Measures should be taken to exclude any danger from electricity (e.g. by complying with the local regulations on electrical equipment). If work is carried out on live electrical components, they should be unplugged from the mains or the main switch turned off and fuse unscrewed. A motor protection switch is to be provided.
- Basically, all work on the pump or pump unit should only be carried out when the pump is stationary and not under pressure. All parts must be allowed to return to ambient temperature. Make sure that nobody can start the motor during such work. It is essential that the procedure for

stopping the system described in the Operating Instructions is observed. Pumps or pump systems that carry media that are dangerous to health must be decontaminated before being taken apart. Safety Data Sheets for the various liquids handled. Immediately the work has been completed, all safety and protective devices must be replaced or restarted.

- Under EC Machinery Directives, every machine must be fitted with one or more emergency command devices by which situations which represent an immediate danger or which could later be dangerous can be avoided. This does not include machines in which the emergency switches cannot reduce the danger, either because they do not reduce the time required to stop the machine or because they do not allow the measures required by the danger to be taken. This emergency switch must:
 - have controls that are clearly marked, easy to see and within easy reach;
 - stop the dangerous movement as quickly as possible without causing any additional danger;
 - trigger any specified safety movements or allow these to be started up.
 If the emergency command device is no longer operated after an emergency "off" switch has been triggered, this must be maintained by blocking the emergency command device until it is released again. It should not be possible to block the device without this triggering an emergency "off" switch. It should only be possible to release the device through an appropriate action; this release should not start the machine up again - it should only make it possible to start it up again.
- If the power supply is interrupted or restored after being interrupted or if it is changed in any other way, this should not cause any danger (e.g. pressure surges).

Speed, Pressure, Temperature

Suitable safety measures must be taken at the plant to ensure that the speed, pressure and temperature of the pump and the shaft sealing do not exceed the limit values given in the in the Confirmation of Order. The given admission pressures (system pressures) must also be sufficiently high.

In addition, the pump must be protected against pressure surges such as can be caused by switching off the plant quickly (e.g. by non-return valve on the pressure side, flywheel, air vessel).

Minimum flows

If the pump is started against a closed pressure line valve, it should be noted that the power taken up by the pump is transmitted to the handled liquid in the form of heat. This can cause the liquid to heat up excessively within a relatively short time, which will then cause damage to the pump's internal fittings. After the pump has reached operating speed, the discharge valve should be opened as quickly as possible. If operating conditions mean that $Q = \emptyset$ is unavoidable, it is essential that a by-pass pipe is provided to protect the pump. We should be pleased to advise on determining the minimum flow or designing the by-pass line.

Back flow

A return flow of the pressure line contents must be prevented when the pump is at a standstill as the back flow speed might be much higher than the operating speed and would destroy the unit.

2. Description

2.1 Model

The sewage pumps series 100 TWS - 100 TWM - 100 TWV are vertical submersible pumps with vortex impeller - suitable for one sense of rotation - close coupled to a submersible motor: They are designed to handle sewage or unscreened waste water containing solids.

Employment



General accident prevention regulations and safety regulations for explosion protection in waste water plants. These Operating Instructions do not contain local safety regulations. The operator is responsible for making sure that they are complied with, this also applies to outside assembly personnel.

Operating Instructions



The unit has an oil filling and must therefore not be used in plants which are directly or indirectly connected to the drinking water supply. In the event of leaks it is to be expected that the liquid handled will be polluted by oil.

Between the two mechanical seals a sealing chamber is provided filled with oil. In the event of leaks it is to be expected that the liquid handled will be polluted by oil.
For special application with food safe oil may be used (upon special request).



If used in swimming pools or garden pools the power supply must be provided by means of an isolating transformer (VDE 0100 § 49 D).

- The maximum permissible depth of installation is 12,5 m.
- The pumps are not self-priming, when they are switched on the impeller must be flooded by the pumped medium (the pumps must either be submersed or be supplied through a suction pipe).
- The water level above the pump must be sufficiently high in order to avoid cavitation.
- The intake of air and the forming of vortices must be prevented.
- The pumps are not suitable for liquids or liquid mixtures which may explode when pumped.
- Velocity of flow in the pipe must be at least 0,8 m/sec.

2.2 Bearing and Lubrication

Bearing

The pump shaft is guided through ball bearings. The bearings are lubricated with grease for life and therefore don't have to be maintained.







Oil filling



When conducting maintenance and repair work or changing oil collect the operating media (e.g. transformer oil) in suitable containers and dispose them in accordance with the applicable national environmental regulations.

The pump unit is filled with oil when delivered and ready for operation. At standard version transformer oil (VDE 0370) is filled in.
Only approved oils must be used.
Special designs: Motors which are filled with white oil are marked with an additional plate and must only be refilled with white oil!

Lubricant list

Lubrication	DIN lubricant identification							
transformer oil	DIN 57370 VDE 0370	Isolan T	Diala D	Univolt 56	Energol JS-R	Eltec GK 2	KG 2	Spezial
white oil				Marcol 52	Energol WM 2		Pharmaceutical 30/40	WO 15

2.3 Shaft sealing

Double mechanical seal in oil bath which may work in both directions, pump side silicium carbide / silicium carbide, motor side carbon / ceramic, springs in oil chamber.

For the monitoring of the shaft sealing a leakage electrode is installed. The measuring wire for the sensor is integrated into the connection cable. The evaluation happens electronically and can be used for switching off or for warning (available against extra charge).

If water gets in contact with the electrode in the seal chamber the duly installed moisture electrode releases a switch-over at the relay. In this case you have to change the oil in the seal chamber. If the electrode signals water in the seal chamber again, only a short period after this oil change, the mech. seal should be checked.

2.4 Installation methods

Unless there is an express agreement to the contrary the unit must only be operated with a vertical shaft (i.e. pump below, motor above).

TWS: Stationary wet installation with automatic quick coupling system and foot.

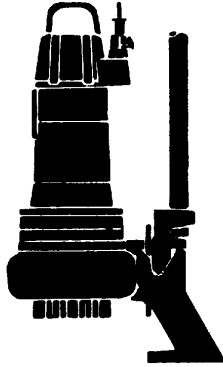

TWM: Wet installation, portable with stand.

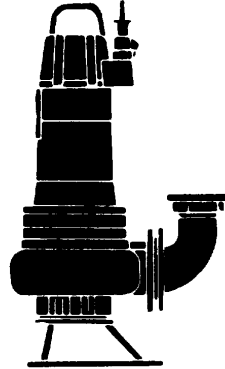

TWV: Dry installation with foot bend (only permissible if stated in the Confirmation of Order).

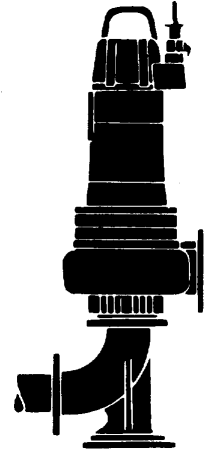

2.5 Technical Data

Motor

Standard design for wet installation of dry enclosed three phase a.c. - squirrel cage motor, protective system IP 68. Cooling results from submersion in the handled liquid. To protect the motor against too high winding temperatures a thermocontact is installed as an opener. On reaching the max. winding temperature it opens the auxiliary circuit and only switches on after the temperature has fallen essentially (alternating voltage 110 - 250 V; max. 1.6A with 250V).

A maximum of 15 starts are permitted per hour.

Your pump's motor design is given in the Confirmation of Order or the type plate.

Wet Installation

Choice of pump: Submersible sewage pump 100 TWM, 100 TWV and 100 TWS with suspension device
Discharge branch DN 100, pump incl. 10 m cable, motor 400 V, 50 Hz, 1450 min⁻¹

Pump type	pump duty		Motor			Cable mm ²	Weight unit kg	Dimensions in mm without obligation										
	Q m ³ /h	H m	P _N kW	J _N A	J _A A			A	B	C	D	E	F	G	H	J	K	
100 TW 190 U 154	20-60	5,5-2,5	1,5	4,2		2x 4x1,5	82	250	416	172	331	125	325	450	595	255	592	
100 TW 200 U 224	20-60	7,5-4,0	2,2	5,3		2x 4x1,5	83	250	416	172	331	125	325	450	595	255	592	
100 TW 210 U 304	20-80	10,5-5,5	3,0	7,0		2x 4x1,5	85	250	416	172	331	125	325	450	595	255	592	
100 TW 220 U 404	20-100	11,5-6,0	4,0	9,0		7+4 x1,5	128	280	473	201	386	140	340	480	652	270	637	
100 TW 235 U 554	20-140	14,0-6,0	5,5	11,9		7+4 x1,5	130	280	473	201	386	140	340	480	652	270	685	
100 TW 250 U 754	20-160	17,0-7,0	7,5	15,7		7+4 x1,5	135	280	473	201	386	140	340	480	652	270	685	
100 TW 260 U1104	20-180	20,0-8,0	11,0	22,5		7x2,5+ 4x1,5	192	280	473	201	386	140	340	480	652	270	757	
100 TW 270 U1504	20-200	22,0-10,0	15,0	30,0		7x2,5+ 4x1,5	194	280	473	201	386	140	340	480	652	270	757	

1) Also for dry installation and liquid temperature up to 30° C, at non-continuous operation S3 (within a cycle of 60 minutes running time).

On wet installation and continuous operation max. permissible liquid temperature is 60° C.

All motors are suitable for continuous operation provided that the motor casing is at least half submerged, however the max. permissible liquid temperature and ambient temperature is 30° C.

In case the water level is lower, derated pump duty for dry installation has to be applied.

Dry Installation

Choice of pump: Submersible sewage pump 100 TWM, 100 TWV and 100 TWS with suspension device
 Discharge branch DN 100, pump incl. 10 m cable, motor 400 V, 50 Hz, 1450 min⁻¹

Pump type	pump duty		Motor			Cable mm ²	Weight unit kg	Dimensions in mm without obligation										
	Q m ³ /h	H m	P _N kW	J _N A	J _A A			A	B	C	D	E	F	G	H	J	K	
100 TW 190 T 134	20-60	5,5-2,5	1,3	3,8		2x 4x1,5	82	250	416	172	331	125	325	450	595	255	592	
100 TW 200 T 184	20-60	7,5-4,0	1,8	5,0		2x 4x1,5	83	250	416	172	331	125	325	450	595	255	592	
100 TW 220 T 454	20-100	11,5-6,0	4,5	11,4		7+4 x1,5	128	280	473	201	386	140	340	480	652	270	637	
100 TW 235 T 454	20-140	14,0-6,0	5,5	11,4		7+4 x1,5	130	280	473	201	386	140	340	480	652	270	685	
100 TW 250 T 624	20-160	17,0-7,0	7,5	14,9		7+4 x1,5	135	280	473	201	386	140	340	480	652	270	685	
100 TW 260 T 804	20-180	20,0-8,0	11,0	19,5		7x2,5+ 4x1,5	192	280	473	201	386	140	340	480	652	270	757	

On dry installation and continuous operation max. permissible liquid temperature and ambient temperature is 30° C.

Transportabel - portable

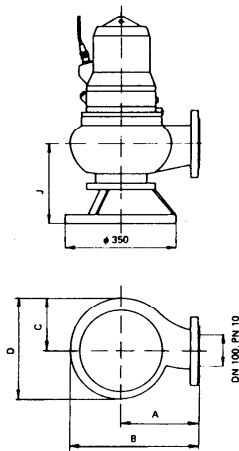

Trocken - dry

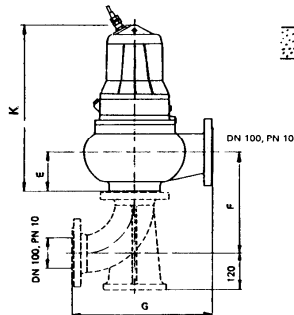

Naß - wet

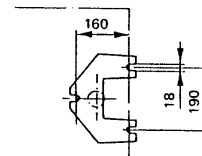
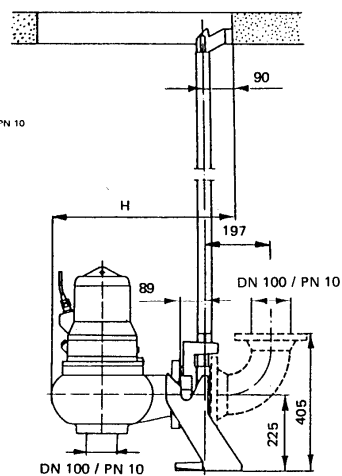

3. Transport, Handling Storage

3.1 Transport, Handling

- Check the pump/pump unit immediately upon delivery/receipt of despatch for damage or missing parts.
- The pump/pump unit must be transported carefully and by competent personnel. Avoid serious impacts.
- Keep the pump/pump unit in the same position in which it was supplied from the factory. Take note of the instructions on the packaging.
- The intake and discharge side of the pump must be closed with plugs or foils during transport and storage.

Attention *Dispose of all packing materials in accordance with local regulations.*

- Lifting devices (e.g. fork-lift truck, crane, crane device, pulleys, sling ropes, etc.) must be sufficiently strong.
- The pump must only be lifted by the carrying handle or the ears.
- For unit weight please refer to para 2.2 "Technical Data".

Attention *Under no circumstances must the unit be lifted by means of the motor cable. Do not damage the cable during transport (do not squeeze, bend or drag). The cable ends must be kept dry.*



Do not stand underneath suspended loads; take note of the general regulations on prevention of accidents. The pump/pump unit must be secured against tipping over and slipping until it has been fixed in its final location.

Checking the oil filling

The pump unit is supplied ready for operation and filled with oil. For safety's sake check that oil is in the unit before starting up.

Small oil leakages on delivery are harmless, they disappear after a short running period.

3.2 Storage

Pumps or pump units that are stored for a long time before use must be protected against moisture, vibrations and dirt (e.g. by wrapping in oil paper or plastic sheeting). Pumps must basically be stored in a place where they are protected from the weather, e.g. under cover. During this period the aspirating holes and discharge branches must always be closed with dummy flanges or plugs or foils. Place the unit upright and secure so that it cannot fall over. Support the cable on the cable entry to avoid lasting deformation (minimum bending radius 15 cm). Protect cable ends from damp.

4. Installation, Operation

4.1 Assembly and connection of pump

Attention *Owing to their great variety there is unfortunately not enough space in these Operating Instructions to repeat all hints and optimal solutions for the construction of pump stations which result from many years of experience. If you have any questions our experts will be pleased to provide you with information.*

- Follow the working conditions (under Point 2.1 "Models").
- To ensure that the pump works trouble-free and has a long life it must be installed so that it is not subject to additional mechanical vibrations from outside. The pump must be fixed in its position. When in operation it must not turn, oscillate or move in any other way. Neither should the pump be stood without support on a slippery base for stationary operation (longer period of operation). The pump must be fastened to the floor, in the pipes or be secured by other devices so that it is fixed in its position. The pump must be fixed to a static, stable system which neither vibrates (or only minimally) nor transmits or reflects vibration. A footbend (dry well installation) or a hanging device (wet well installation) directly on the floor of a solid construction (or shaft) are suitable for securing the pump. Also see Point 2.1 "Installation Methods". If the transportable pump model is operated over a long period at the same place we recommend that it is attached to the floor. This will prevent vibrations and resulting damage to components and the pump.
- The pump duty depends on the correct sense of rotation. Hence it is essential to check the sense of rotation before the installation: when started the direction of the starting impact must comply with the arrow "Reaction" cast onto the motor casing. On wrong rotation change two phases at power supply (ref. para 4.4 "Electrical connection"). A short test run will not harm the pump.



When checking the sense of rotation make sure that the unit is in a safe condition. Do not hold the unit with or in your hands when switching on. The sense of rotation can also be checked after initial operation (see Point 4.4).

- When using a hanging device for wet well installation follow the instructions for the hanging device.
- For automatic operations the level switch must be set so that the pump casing is still flooded at the lowest water level.

Attention *Sufficient space must be provided for maintenance and repair work, especially for replacing the drive motor or the complete pump unit.*

Mounting of discharge pipe and/or suspension device at pumps of design TWS

How to arrange the components is shown at dimension drawing para 2.2 Technical Data.

At designs TWM (with stand for portable application) and TWV (with duck foot bend for dry installation) the following points must be observed:

- Fix guide rail holder.
- Cut guide rail (pipe DN 32, DIN 2440).
- Fix coupling foot onto bottom of pit that way that the guide rail leads vertically to the upper holder. It is advisable to bolt the coupling foot to a baseplate and to fix the baseplate onto the bottom of the pit in order to increase the support area of the foot.
- Arrange discharge pipe and take care that all fittings (flanges, valves, non return valves etc.) are kept clear from the guide rail by at least 32 mm.

4.2 Connecting the pipes to the pump

Attention *When laying the pipes, make sure that the pump is accessible for maintenance and installation.*

- If the unit is for dry installation it must be connected tension-free and free of vibration to the suction pipe and pressure line. The pump may not be used to support the pipes. The pipes must be proportioned so that there is a perfect flow to the pump and that the function of the pump is not restricted. When laying the suction pipe the general rules for the arrangement of suction pipes must be followed.
- When emptying the pipe after the pressure test, make sure that the pump is treated properly (danger of rust and problems when starting up).

4.3 Mounting of pump by means of suspension device

Provide lifting device (payload min. 200 kg), hang pump at eye bolts and lower it following the guide rail until it fits into the coupling foot. The pump hangs inclined which prevents damaging of lip seal during lowering. The seal will fit into its place when the lowering is finished and the pump rests on the coupling foot. When pulling up the pump will turn out of its seat first thus protecting the lip seal again.

4.4 Electrical connection



Electrical connection work must only be carried out by an authorised professional. The rules and regulations valid for electrical technology, especially those concerning safety measures, must be observed. The regulations of the national power supply companies operating in that area must also be observed.

Before starting work, check that the information on the motor rating plate is the same as the local mains network. Effect the connection over a motor protecting switch, preferably with an ammeter and an inert fuse.

A reliable motor protection switch is to be provided.

On bigger motor power the power supply company may require star delta starting, also equipped with thermal overload relays. On automatic operation the float switch will activate the contactor and hence control the pump.

The setting value of the motor protection switch is given on the rating plate. Permissible voltage tolerance +6% or -10%.



The leakage electrode and the temperature guard must be connected, otherwise the guarantee for the pump unit becomes invalid.

Motor Protection

Leakage electrode:

A leakage electrode is installed in the oil chamber in order to protect the motor. The maximum working voltage is 30 V. A release device is required.

Temperature guard as opener:

When reaching the max. temperature this device opens the auxiliary circuit and only switches on after essential change of temperature.

Max. allowed current on alternating voltage 250 V 1.6 A.

Attention *Isolation check of temperature sensors with max. 300 V AC.*

Sense of Rotation

For control of sense of rotation refer to point 4.1. The change of the sense of rotation takes place through the change of two arbitrary conductors on the net side of the unit, e.g. L1 through L2 or L3 through L2.

Designation of Connection

The motors are provided with two cables. The left cable 4 x 1,5mm², seen from above, is intended for the motor protection. The right cable is for the motor connection.

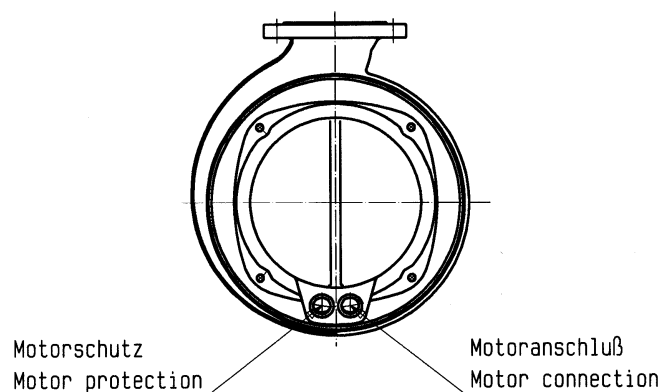
**Motors up to 3 kW are designated for direct start-up.**

The single leads are marked as follows:

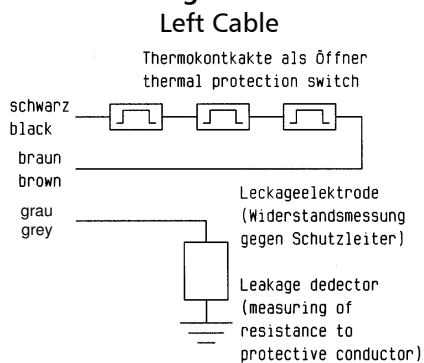
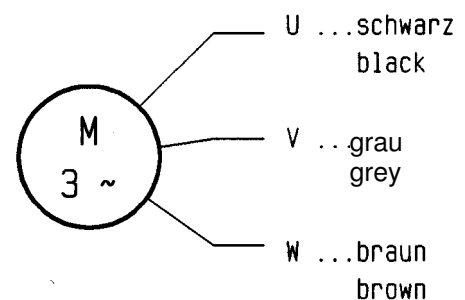
Cable marking:**Right Cable**

If the marking gets lost, measure the resistance to find out the motor cable: each phase of the motor has conduit against the other phases (e. g. black against blue resp. brown).

Motors with performances >3 kW are designated for Star-Delta start-up.
The single leads are marked as follows.

Cable marking:

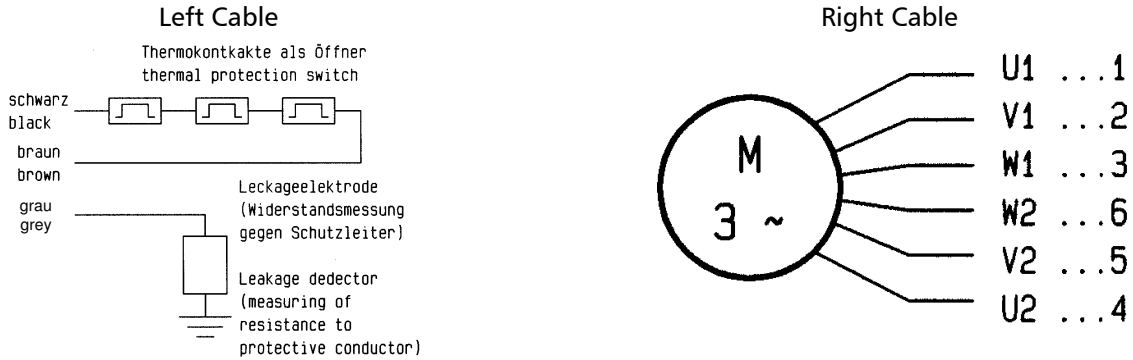

Control

Two level switches are required for controlling the pump automatically, acc. to their position. The cable length of motor and level switches is 10 m. On an automatic control the upper level switch is intended for the switch-on contact while the lower one is for the switch-off contact. The pear shaped level switches can not get untight. Because of their large volume they are safe from settling of textiles, fibres etc. which might hinder the proper function. They are also chemically resistant to most liquids. The contactor which starts and stops the pump motor must be of impulse contact type.

If there are two or more pumps in use provide a switch-over relay in order to change the starting frequency of the pumps and to prevent pumps, which are not in use, from getting stuck.

The control must be designed in a way, that the temperature detectors can only be re-started by hand after a switch-off (auxiliary relay with separate manual reset button or complete relay with integrated manual reset button and signal lamp)

Alarm switches

Upon request an additional level switch can be provided to prevent overflow by raising an alarm. It may be operated by a battery to be functional also if there is no power.

Mounting of level switches

The switches hang on their cables which are to be fixed at a cable holder. The switching level is where the cable enters the switch body. Take care that the switch can move freely.

Electrical connection

(Wiring diagram for dol starting)

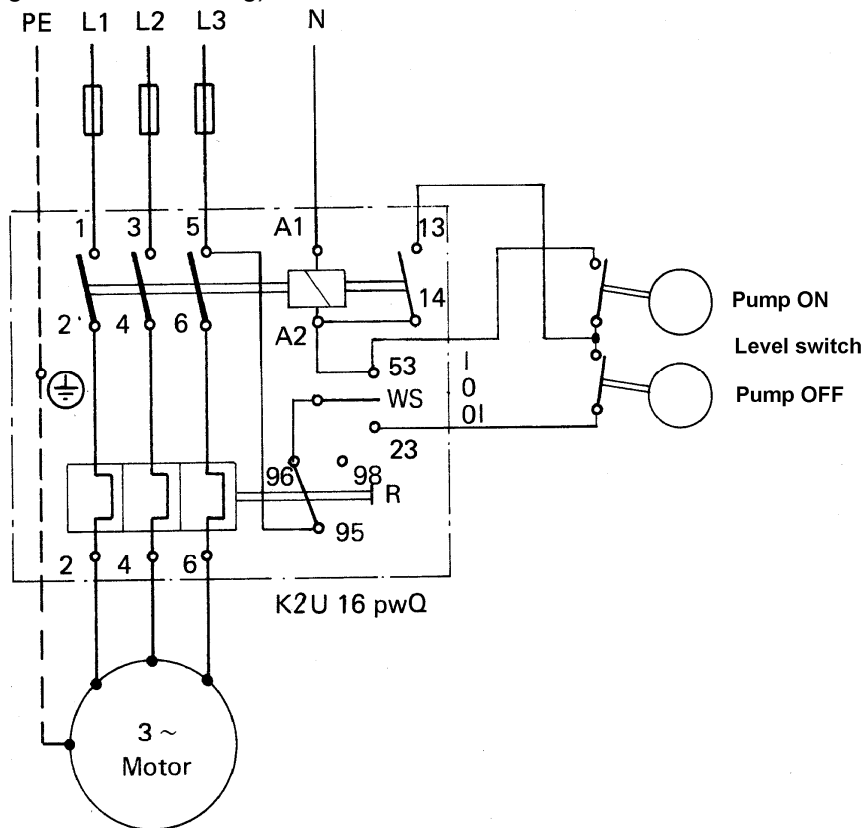

Rating of level switch contact : 250 V ~, 2 Amp.

4.5 Starting up



The plant must only be started up by people who are familiar with the local safety regulations and with these Operating Instructions (especially with the safety regulations and safety instructions given here).

Starting up for the first time

Before installation

Inlet chamber, pumping pit and feeding pipes must be cleared of building debris and other solid materials before the pumps are installed and taken into operation (above all with new installations).

After installation and before switching on

- Flood the pump unit. The pump casing must be completely filled with the pumped medium and ventilated (through vent screw on the discharge branch or by ventilating the non-return valve).
- Open any suction side valves.
- Check setting of level switches (the lowest water level must guarantee sufficient water cover, see Point 4.1 "Assembly and Connection of Pump").
- Do not stand in the danger zone of revolving parts. Due to function there is no protection device.
- Do not stand in the danger zone of live or pressurised parts. Check that all filling plugs, drain plugs and vent plugs are properly secured.
- Work on the pump must only be carried out when the current has been switched off and the movable parts are no longer turning. Switching on by unauthorized persons is to be prevented by appropriate measures.
- In case of failure, e.g. motor does not start, fuses blow or the motor protection switch is activated immediately, on no account should you repeat the starting procedure (danger of excess pressure in motor due to impermissible warming). Detect cause of failure and repair.
- Check protection devices.

After Switching On

- The sense of rotation can also be checked after switching on. This is done by comparing the flow rate and running noise of the pump. To change the sense of rotation, see Point 4.3. If the sense of rotation is correct, the flow rate will increase and running will be quieter.
- Check current uptake and running of machine.
- If faults occur, see chapter 7 "Faults - Causes and Solutions".

Restarting

Basically, the same procedure should be followed as for starting up for the first time. However, there is no need to check the direction of rotation of the pump unit.

4.6 Operation and Monitoring



Be particularly careful not to touch hot machine parts when working in the unprotected shaft seal area. Remember that automatically controlled systems may switch themselves on suddenly at any time. Never put your hands in the pump casing unless it is absolutely certain that it is impossible to switch on the unit. Suitable warning signs should be affixed.

Attention *Regular monitoring and maintenance will extend the life of your pump or pump system.*

- You must observe the area of application given in the Confirmation of Order.
- Do not exceed the output given on the motor rating plate.
- Running against closed discharge valves or operation whilst the handled liquid is in the vapour phase.
- On units for wet installation take care that the whole unit is flooded.
- Avoid sudden changes in temperature (temperature shocks).
- The pump and motor should run evenly and without vibrations; check at least once a week.
- Pumps which are exposed to corrosive chemicals or to wear through abrasion must be inspected periodically for corrosion or wear and tear. The first inspection should be carried out after six months. All further inspection intervals should be determined on the basis of the state of the pump.
- Check protection devices.

4.7 Shutting down

- Close slide valve in discharge pipe. This is not necessary if there is a spring-loaded non-return valve.
- Switch off motor (make sure it runs down quietly).
- If there is any risk of freezing, empty pump and pipes completely.

4.8 Dismantling



The operator's or manufacturer's fitters should be informed as to the nature of the liquid handled. In the case of pumps handling dangerous liquids, the liquid handled should be disposed by environmentally acceptable means before the pump is dismantled.

- Before starting to disassemble the pump unit make sure that it cannot be switched on again.
- The pump casing must be depressurised and empty.
- All valves in the suction, intake and discharge pipes must be closed.
- All components must have cooled down to ambient temperature.

5. Maintenance, Servicing



Work should only be carried out on the pump or pump unit when it is not in operation. You must observe Point 1.4 "Safety instructions". The oil in the sealing chamber or in the motor chamber can be pressurised. Therefore the locking screw may only be opened slowly and with great care. The screw must only be completely loosened or removed after complete pressure compensation.



When conducting maintenance and repair work or changing oil collect the operating media (e.g. transformer oil) in suitable containers and dispose in accordance with the applicable national environmental regulations.

Attention *Maintenance and servicing work must only be carried out by trained, experienced staff who are familiar with the contents of these Operating Instructions, or by the Manufacturer's own service staff. The work carried out must be duly entered in the "Log Book" (see Point 11) and confirmed by being signed.*

- With a new pump unit or after fitting a new shaft sealing check the oil level in the motor chamber after one week.
- Check power consumption each month with an ammeter. If operations are normal the power consumption will be constant. Occasional power fluctuations can result e.g. from alterations to the mixture of the liquid pumped.
- Check the oil level in the sealing chamber every 1000 operating hours, but at least every six months. If there are heavier oil leaks check the shaft sealing. Do not forget the seal under the screw plug.
- When used for normal operations a thorough inspection should be undertaken once a year. In the case of very dirty or sandy water this inspection should be carried out at shorter intervals
- Pump parts - impeller, casing, suction branch, sealing flange and, with closed impellers, the split ring, should be checked for wear. Replace defective parts. Greater play between the impeller and the split ring due to wear reduces the capacity of the pump.
- Roller bearings are prelubricated and maintenance free. If the unit runs noisily or the shaft moves sluggishly (rotate by hand), the motor requires a general overhaul.

Change of oil

In order to ensure trouble free operation, the oil should be changed once a year. For doing this the pump must be pulled up and the oil drained by opening the body (10), when the pump is in horizontal position, drain plug (AS) at bearing. In case you find water in the oil the mechanical seal may be damaged and you should contact your pump supplier at any other pump specialist for repair. If no water is contained in the oil flush the oil chamber with petrol and fill again with transformer oil (ref. para 2 "Lubricant list") with the pump still in horizontal position at the filling plug (FS). The required oil quantity is at motors U 154, U 224, U 304, T 134 and T 184 appr. 2 litres and from U 404 respectively T 454 appr. 4,2 litres. The required air cushion builds on its own through the shape of the oil chamber.

Cleaning the pump

Dirt on the outside of the pump has an adverse effect on transmission of heat. The pump should therefore be cleaned with water at regular intervals (depending on the degree of dirt). Make the pump running for a short time in clear water to prevent crusts.

General overhaul

A general overhaul of the machine is only necessary if the roller bearings are defective or on a submersible motor which is not ready for operation. Work must be carried out by the manufacturer or by partner workshops. See also Point 8 "Repairs".

Alarms

Check alarm switch once a month for proper function. If there is no alarm switch the working of the control switches should be checked.

6. Longer periods of non-operation

Attention When starting up, follow the instructions for starting up for the first time (see Point 4.4)!

6.1 Pumps which have not been installed

- Store as described in Point 3.2.
- Review oil filling after 2 years.
- Before installation check that the rotor runs smoothly (turn by hand). If necessary, unblock by tapping gently on the shaft in axial direction.

6.2 Pumps which have been installed

- Switch stand-by pumps on and immediately off again once a week.
- Review oil filling after 2 years.

7. Faults - Causes and Solutions



If the motor was switched off by a protection device: do not restart, first find and repair the fault.

The following notes on causes of faults and how to repair them are intended as an aid to recognising the problem. The manufacturer's Customer Service Department is available to help repair faults that the operator cannot or does not want to repair. If the operator repairs or changes the pump, the design data in the Confirmation of Order and Points 1.2-1.4 of these Operating Instructions should be particularly taken into account. If necessary, the written agreement of the manufacturer must be obtained.

Faults	Code no. for cause and method of repair
Motor does not start, fuses melt or the motor protection switch is released immediately. Do not repeat start	1, 2, 3, 4
Machine starts but the motor protection switch is soon released	5, 6, 7, 8
Machine runs, output and power consumption are below normal values	9, 11
Machine runs but does not pump	10, 11, 12
Flow rate too low	3, 7, 9, 10, 11, 12, 13, 14, 16, 17
Pump does not run smoothly and makes noise	7, 14, 15, 16, 17, 18, 19
Pump does not stop	20

Meaning of code number for cause and method of repair

1. Disruption in the supply cable, short circuit, earth fault in the cable or motor winding.
 - Have cable and submersible motor checked by a qualified electrician and repair faults
2. False fuses release
 - Fit slow fuse in accordance with the Rating Plate.
3. Impeller blocked by foreign bodies.
 - Unblock impeller (make sure that pump cannot be turned on accidentally during work.
4. Check automatic level switch
5. Thermal release on the motor protection switch is set too low.
 - Have a specialist compare the setting of the release with the Rating Plate and readjust.
6. Increased power consumption due to higher drop in voltage. (Power cable lengthened.).
 - Measure voltage between the phases on the motor. Permissible tolerances +6%, -10%.

7. Increased power consumption because of two phase delay.
 - Measure voltage on the three phases. If the voltage is not the same on 3 phases, check the fuses and contacts in the contactor and renew if necessary.
8. Impeller is slowed down by solid materials.
 - Excessive power consumption in all 3 phases. Clean pump (make sure that pump cannot be turned on accidentally during work).
9. Clean blocked impeller (make sure that pump cannot be turned on accidentally during work). Check sense of rotation.
10. Ventilate pump.
11. Pump takes in air
 - Increase flooding.
12. Defective pressure line or flange gaskets.
 - renew
13. Pump pumps against pressure which is too high
 - Open shut-off devices
 - After consultation with the factory fit larger impeller
14. Wrong sense of rotation
 - Swap 2 phases of the network supply
15. Impermissible operating range
 - Check operating data
16. Intake blocked
 - clean
17. Internal pump components worn.
 - renew
18. Motor bearings defective.
 - renew
19. Unit installed under tension.
 - Check pipe to see if pipe connections are tension-free.
20. Check control switch, it may be blocked or out of order.

8. Repairs



Repairs to the pump or pump system must only be carried out by authorised skilled personnel or by the manufacturer's specialized staff.

We would be pleased to send you detailed repair instructions on request. Trained Customer Service engineers are available to assist with installation and repair work on request.

When removing the pump or the motor, you must comply with Point 1.4 "Safety instructions", Point 3.1 "Transport, Handling" and Point 4.8 "Dismantling".

9. Spare parts, Spare pumps

9.1 Spare parts



To ensure optimum availability, we recommend that suitable quantities of spare parts are held in stock, especially if these are made from special materials and in the case of mechanical seals, because of the longer delivery times.

Ordering spare parts

When ordering spare parts, please supply the following information:

Type: _____

Order no.: _____

Sectional drawing: _____

Part designation: _____

All the information is given in the Data Sheet and the relevant sectional drawing.

9.2 Stand-by pumps



It is essential that a sufficient number of stand-by pumps are kept ready for use in plants where failure of a pump could endanger human life or cause damage to property or high costs. Regular checks should be carried out to ensure that such pumps are always ready for use (see Point 6.2).

10. Plant Manager List

Each plant manager should sign below to confirm that he has received, read and understood these Operating Instructions. He undertakes to follow the instructions conscientiously. If these instructions are not followed, the manufacturer's guarantee and liability shall cease to apply.

Name:	Date:	Signature:

11. Log Book

Each plant operator shall duly enter all maintenance and service work that has been carried out, and shall take care that the person responsible confirms such work by signing below.

Maintenance work:	Date:	Signature Plant operator	Confirmed by person responsible:

Sectional drawing with leakagedetector 100TW

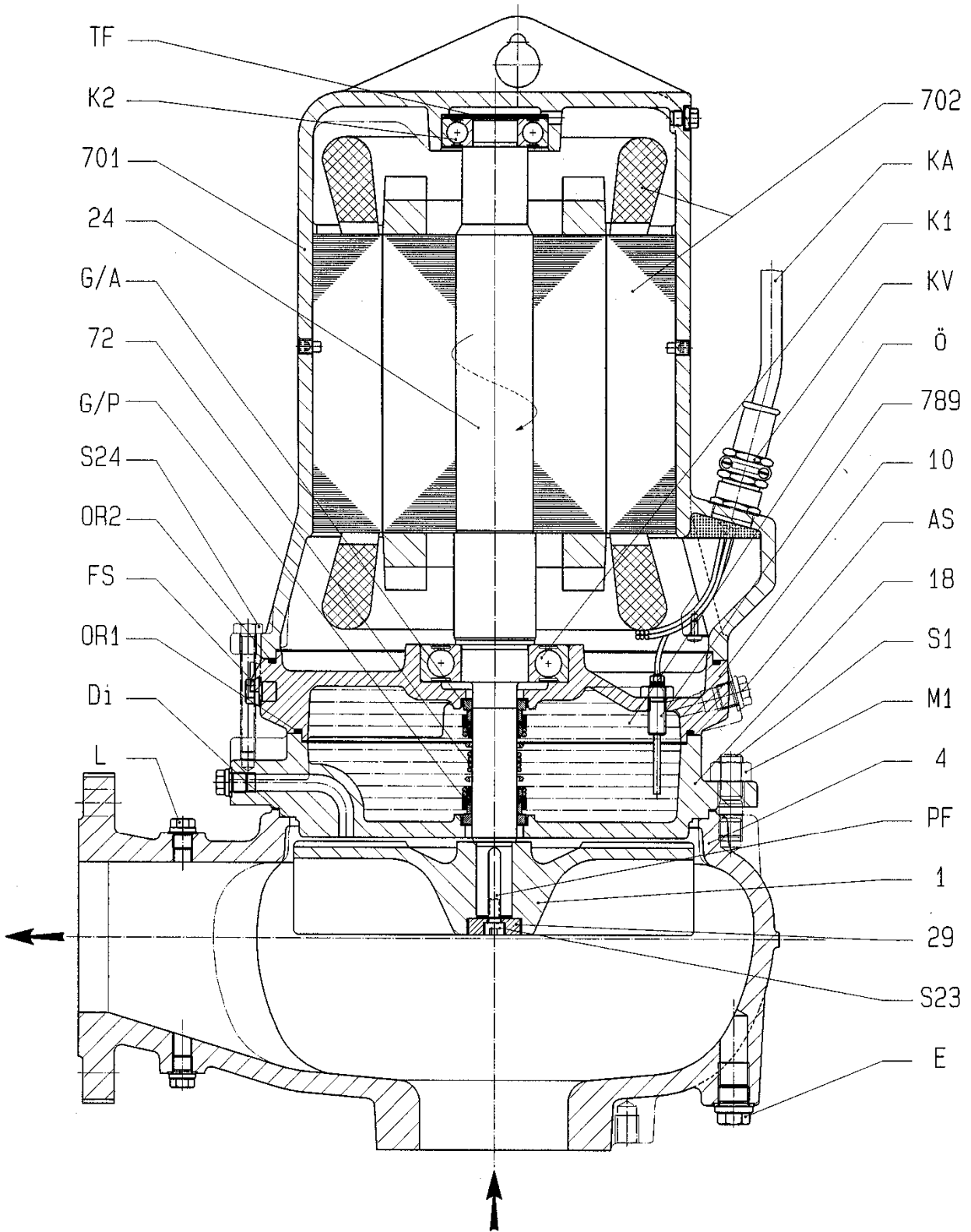

This leaflet is subject to alteration without notice!

Teilbezeichnung	Nomenclature	Index of Parts	Europump Nr.
1 Laufrad	roue	impeller	2200
4 Pumpengehäuse	corps de Pompe	pump casing	1110
10 Lagerschild	boitard de roulement	bearing carrier	3240
18 Zwischenwand	corps-entretoise	intermediate cover	1221
24 Welle + Läufer	arbre + rotor	shaft + rotor	2100+8130
29 Laufradscheibe	rondelle de roue	impeller fixing washer	-
72 Paßscheibe	rondelle de distance	distance washer	-
701 Motorgehäuse	carcasse de ´moteur	motor casing	8110
702 Statorpaket + Wicklung	paquet de toles stator + bobinage	stator lminations + windings	8140+8150
789 Leckageelektrode	sensor de voite	leakagedetector	-
AS Ölablaßschraube	vis de vidange d ´huile	oil drain plug	-
Di Gehäusedichtung	joint de corps	casing joint	4510
E Entleerungsschraube	bouchon de vidange	drain plug	6515
FS Ölfüllschraube	bouchon de remplissage d ´huile	oil filter plug	3854
G/A Gleitringdichtung, antriebsseitig	joint mecabique, côté commande	machanical seal, drive side	4200
G/P Gleitringdichtung, pumpenseitig	joint mecabique, côté pompe	machanical seal, pump side	4200
K1 Kugellager, pumpenseitig	roulement a billes, côté pompe	ball bearing, pump side	3011
K2 Kugellager, endseitig	roulement a billes, côté commande	ball bearing, drive side	3011
KA Kabel	cáble	cable	8360
KV Kabelverschraubung	presse-étoupe de cable	cable gland stuffing box	8370
L Entlüftungsschraube	vis de purge d'air	air vent plug	-
M1 Sechskantmutter	écrou á six pans	hexagonal nut	-
OR1 O-Ring	bague O	O-ring	4610
OR2 O-Ring	bague O	O-ring	4610
Ö Ölfüllung	huile	oil	-
PF Paßfeder für Laufrad	clavette de la roue	impeller key	6710
S1 Stiftschraube	goujon	stud bolt	-
S23 Innensechskantschraube	vis avec tête á six pans	hexagonal socket screw	-
S24 Sechskantschraube	vis á six pans	hexagonal screw	-
TF Tellerfeder	ressort Bellville	plate spring	-

Branch offices

ITT Austria GmbH

Ernst Vogel-Straße 2
A-2000 Stockerau

Telefon: (+43) 2266/604

Telefax: (+43) 2266/65311

E-Mail: info.ittaustria@itt.com

Internet: www.ittaustria.com